

YUTECH FLUID-DENSITY-BRIX ANALYZER CUM CONTROL SYSTEM AND MOTORIZED FLUID-DENSITY SENSOR

PRESENTATION AND DATASHEET



YUTECH



TM

YUTECH FLUID-DENSITY-BRIX ANALYZER CUM CONTROL SYSTEM



MOTORIZED FLUID-DENSITY SENSOR



YUTECH

Servicing the Sugar Industry since 1978

YU Technologies Pvt. Ltd.

HO & Works: B 8/5, MIDC, Miraj, 416 410, Distt: Sangli, Maharashtra, India. T: +91 233 2644042, +91 916 832 4851, +91 916 832 5127 / 8.

E: info@yutech.in; sale@yutech.in W: www.yutech.in; www.yutechautomation.com

www.yutechautomation.com; www.yutech.in; sale@yutech.in

YUTECH FLUID-DENSITY-BRIX ANALYZER CUM CONTROL SYSTEM AND MOTORIZED FLUID-DENSITY SENSOR

BASED ON YUTECH'S A15 INTELLIGENT ANALYZERS AND SYSTEMS PLATFORM



YUTECH



**FLUID-DENSITY-BRIX ANALYZER AND
CONTROL SYSTEM**

YUTECH FLUID-DENSITY-BRIX ANALYZER CUM CONTROL SYSTEM

PRODUCT CODE:

ANALYZER MODEL: A15FDAACSCTRC1D4R4FM,

ANALYZER AND CONTROLLER MODEL: A15FDAACSCTRC2D4R4FMC

ANALYZER AND CONTROLLER WITH ETHERNET MODEL:

A15FDAACSCTRC2D4R4FMCEM (Modbus TCP/IP)

MOTORIZED FLUID-DENSITY SENSOR

PRODUCT CODE: ASDMFDS24DCC01



MOTORIZED FLUID-DENSITY SENSOR

INTRODUCTION

BASIC SCIENCE BEHIND FLUID-DENSITY-BRIX:

- **Fluid-Density:** the Density of a particular Fluid.
- **Density:** is defined as “**Mass per unit volume**”, which means, Density is the Mass contained in a fixed volume. It is denoted by “ **ρ** ” which is a Greek Letter called “Rho”.
- **Density** can be derived using the formula “ **$\rho = m/v$** ” where ρ is the Fluid-Density, m is the Mass and V is Volume. The unit to measure Fluid-Density is **kg/m^3** (Kilogram per cubic meter).
- **Brix:** the measurement in percentage by weight of sucrose in pure water solution.
- Online Direct measurement of Brix in a Process Fluid is difficult, so indirect methods are used.
- **The most popular ways of measuring Brix are:**
 - **Hygrometric and Refractometric (Lab Methods)**
 - **High-Frequency or Radio-Frequency Conductivity type Brix Sensing**
 - **Microwave Type Brix Sensing**
 - **Fluid-Density Type Brix Sensing**
- While Conductivity or Microwave methods are very successful in measuring Brix of “B and C” Masecuite in CVP, Brix of Sugar Melt, and Brix in a Molasses Conditioner unit, they cannot measure Brix of “A” Masecuite as we measure the Fluid’s electrical quality which is variable.
- Fluid-Density Measurement using a Motorized Stirring Sensor proves very successful as it directly measures the Fluid’s mechanical quality of Fluid irrespective of its electrical characteristics. Thus, measured Fluid-Density Value is further processed in the **Fluid-Density-Brix Equation**, to derive **Fluid-Density-Brix**.

SALIENT FEATURES

- Fluid-Density Type Brix Analyzer System targets sensing the Fluid-Density of Liquids, Slurries, or Syrups like Sugar Masecuite, Sugar Syrup, Sugar Melt, Liquors, and Molasses.
- The Motorized Fluid-Density Sensor is specially designed to be inserted in a vessel to stir the Fluid Media and Measure its Fluid-Density which can be expressed in simple terms as the Tightness or Thinness of a Fluid Media. It can also be informally referred to as the Consistency of the Fluid and is a Mechanical Property of a Fluid which in Liquids is directly proportional to its Viscosity.
- Motorized Sensor's torque and power which is required to stir the Fluid varies with varying Fluid-Density.
- The Motorized Fluid-Density Sensor's Power Consumption is directly proportional to the Fluid's Density.
- The variation in the Motorized Fluid-Density Sensor's Power Consumption is sensed by the Fluid-Density Type Brix Analyzer's highly accurate Sensing Circuitry, this deviation is further processed to Derive the Raw Fluid-Density Value.

SALIENT FEATURES

- The Raw Fluid-Density Value is Linearized in the YUTECH Fluid-Density-Brix Equation.
- The **YUTECH** Fluid-Density-Brix Equation is a complex Algorithm with Built-in Fuzzy Logic that Accurately Analyzes, Calculates, and Derives the Fluid-Density-Brix Value from the Raw Fluid-Density Value.
- This derived Fluid-Density-Brix Value is further analyzed and processed to compensate for Masecuite / Syrup Level variation within the Vessel.
- Fully Compensated and Accurate Fluid-Density-Brix Value is Displayed and Transmitted for Controls.
- Very Easy Calibration and Online Fluid-Density-Brix Compensation Recalibration
- 4-20 mA Output, Separate Modbus and Ethernet Communications.
- On-line Calibration Software “YUTECH-AccessApp” provides Remote Access to Consistency-Brix Analyzer for Calibration, Compensation, and Trouble Shooting.

APPLICATIONS

APPLICATION IN SUGAR PROCESS OR SUGAR REFINERY FOR MEASURING FLUID-DENSITY-BRIX OF MASSECUTE / SYRUP / MELT / LIQUOR / MAGMA / SEED IN:

- Vertical Continuous Vacuum Pan (VCVP or VKT) Chambers
- Batch Type Vacuum Pans and Continuous Vacuum Pans
- Sugar Melters and Molasses Conditioners
- Evaporators
- Open Pans in Khandsaris or Mini Sugar Plants / Jaggery or Muscovado Plants
- Boiling Vessels in Jaggery or Muscovado Production

FLUID-DENSITY MEASUREMENT APPLICATION IN OTHER PROCESS INDUSTRIES:

- **FOOD & BEVERAGES:** In Vessels or Pans for Monitoring the Consistency of Sauces / Slurries / Pastes etc.
- **CHEMICAL / PHARMA:** In Thickening / Thinning Vessels or Pans for Monitoring the Consistency of Chemical Slurries / Pastes
- **DISTILLERIES:** In Fermentation / Maturation Vessels and Spent-Wash Evaporators for Monitoring Brix
- **BREWERIES:** In Fermentation Vessels for Monitoring Brix Fermentation Vessels, Maturation Tanks

SALIENT FEATURES

Innovative Features for Ease of Operation and to save on Installation Cost and Materials:

- **Built-in Fluid Consistency-Brix Equation**
- **Built-in Level Compensation**
- **Built-in PID Controller:**
 - Highly Accurate Fuzzy Logic PID Controller developed especially for Process Control and Flow Control Applications.
 - Pan Control Logic built especially for Batch type Vacuum Pan Operations
 - VC Pan Chamber Control Logic built especially for Vertical Continuous Pan Operations
 - CVP Pan Chamber Control Logic built especially for Continuous Vacuum Pan Operations
 - Melter and Molasses Conditioner Control Logic
 - Remote Set Variable Facility
- **Built-in 3-Point Auto/Manual Station to Select Control Output from:**
 - Selector Switch for Local PID Output or DCS/PLC PID Output
 - Manual Output for Trouble Shooting

This feature simplifies installation by eliminating need for installing a Junction Box and Extra wiring.

SALIENT FEATURES

Innovative Features for Ease of Operation and to Save on Installation Cost and Materials:

- **Built-in Communications:**

- **Ethernet:**

- **Modbus TCP/IP Ethernet Communication Protocol / Ethernet TCP/IP**
- **Analyzer Calibration Facility from DCS / PLC- SCADA / HMI System**
- **External PID Controller Calibration Facility from DCS / PLC- SCADA / HMI System via Ethernet. Control Variables can be accessed and changed from DCS / PLC- SCADA / HMI.**
- **Brix Data is Communicated for Data Acquisition and Data Storage within DCS / PLC- SCADA / HMI.**

- **RS485: Modbus RTU on request in Base Model.**

- **USB Communication Facility: For Calibration from PC or Android using System's USB Port. (This facility is available only in Controller with Ethernet Models).**

- **YUTECH Access App: Calibration Software can be installed in a PC or Android.**

TECHNICAL SPECIFICATIONS – ANALYZER CUM CONTROL SYSTEM

- **Power Supply:** 85 - 265 VAC, 50 – 60Hz
- **Analyzer Enclosure:** IP67 Field Mounted Dust and Moisture Proof
- **Input:**
 - Fluid-Density Sensor Signal
 - RTD PT 100 Temperature Sensor Signal
 - DPT Level Transmitter Signal
 - VFD RPM Signal (Optional)
 - Conductivity 8-Level Sensor Signal
- **Calibration:**
 - From Keyboard
 - USB Port for Windows / Android-based YUTECH-AccessApp-BA
- **Display:**
 - Base Model: 4 Digit LED Dual Display
 - Controller and Controller with Ethernet Model: 4 Digit LED Quad Display
 - Sensor Cleaning and Washing Output: In-Built Potential Free Relay
- **Sensor Cleaning Timing Cycle:** Adjustable from Keyboard, default 15 Minutes
- **Signal Output:**
 - 4 - 20 mA Temperature Compensated Brix Output
 - 4 - 20 mA PID Output (Controller and, Controller with Ethernet Models)
 - 2 Potential-Free Relay Outputs for High – Low Alarm
- **Communications:**
 - Ethernet Communication Protocol: Modbus-TCPIP, in Controller with Ethernet Model
 - Modbus RTU, in Controller Model

TECHNICAL SPECIFICATIONS – MOTORIZED FLUID-DENSITY SENSOR

MOTORIZED FLUID-DENSITY SENSOR (PRODUCT CODE: ASDMFDS24DCC01):

- Motorized Circulator or Stirrer stirs the Fluid whose Fluid Density is to be measured.
- Power consumed
- MOC: Wetted parts: Stainless Steel (SS316) / PTFE. Non wetted parts: SS / MS / Aluminium / PTFE.
- MOC: All SS and Food Grade PTFE Construction optional.
- MOC: Wash Water Spray Tube: SS.
- Solenoid Valve for Automatic Sensor Wash
- Sensor Shaft is sheathed in Leak Proof Mechanism.
- Periodic Cleaning by a signal from the Fluid Consistency Brix Analyzer.
- 24VDC Power Supply.

TEMPERATURE SENSOR:

- RTD PT 100 Temperature Sensor with Thermowell constructed out of Solid SS Bar.

LEVEL SENSORS:

- DPT with Extended Diaphragm and Capillary Type Sensing
- 8-Level Conductivity Sensing (MOC: SS316 / PTFE)

TECHNICAL SPECIFICATIONS

Product Code:

- A15FDAACSCTRC1D4R4FM – A15FDA means Fluid-Density Analyzer of A15 Product Family
- A15FDAACSCTRC1D4R4FM – AC Power Supply
- A15FDAACSCTRC1D4R4FM – Analog Inputs and Outputs
 - AI (CSCTR): Fluid-Density Sensor, 8 Step Level, and RTD PT100, Optional: 4-20mA from DPT Type LT;
 - AO (C1): 1 Ch. 4-20mA (Brix), AO (C2): 2 Ch. 4-20mA (Ch. 1: Brix and Ch. 2: PID)
- A15FDAACSCTRC1D4R4FM: Digital Inputs and Outputs
 - DI (D4): 4 DIs (24VDC); DO (R4): 4 Relay Outputs (24VDC, 1A)
- A15FDAACSCTRC1D4R4FM – Field Mounted Enclosure
- A15FDAACSCTRC2D4R4FMC – Analyzer with Controller Model
- A15FDAACSCTRC2D4R4FMC – Analyzer with Controller and Ethernet Model, EM: Modbus TCP/IP Communication (Ethernet)
- **Calibration:**
 - Please mention the application for factory calibration as illustrated below:
 - Vertical Continuous Pan
 - Batch Pan A / B / C
 - Horizontal Continuous Vacuum Pan
 - Molasses Conditioner
 - Sugar Melter
 - Evaporator

YUTECH FLUID-DENSITY-BRIX ANALYZER CUM CONTROL SYSTEM AND MOTORIZED FLUID-DENSITY SENSOR

FFE AUTOMATION - EVAPORATOR CONTROLS SCHEMATIC AND SCREENSHOT



YUTECH

FALLING FILM EVAPORATOR (FFE)

AUTOMATION:

- EVAPORATOR LEVEL MAINTAINED FOR PROPER EVAPORATION AND VAPOR GENERATION.
- AUTOMATIC WATER INTAKE IF REQUIRED.
- INLET FLOW TO THE FFE BODY AND RECIRCULATION IN EQUAL OR IN PRESET PROPORTION.
- OPTIONAL INLET, RECIRCULATION AND BYPASS FLOWS MEASUREMENT AND CONTROL.

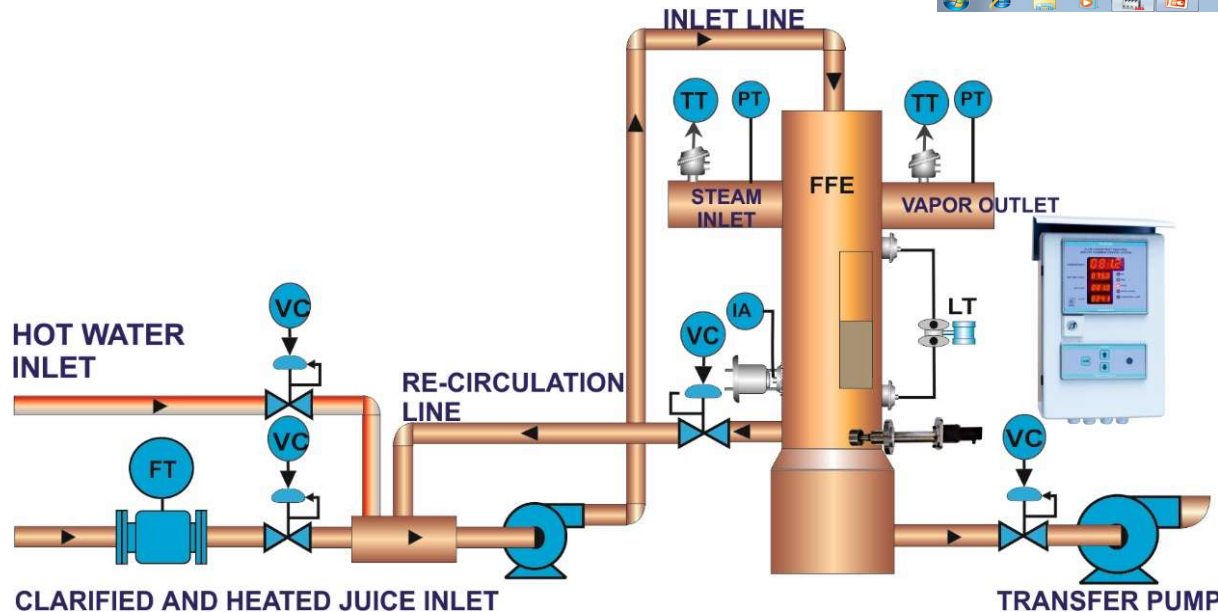
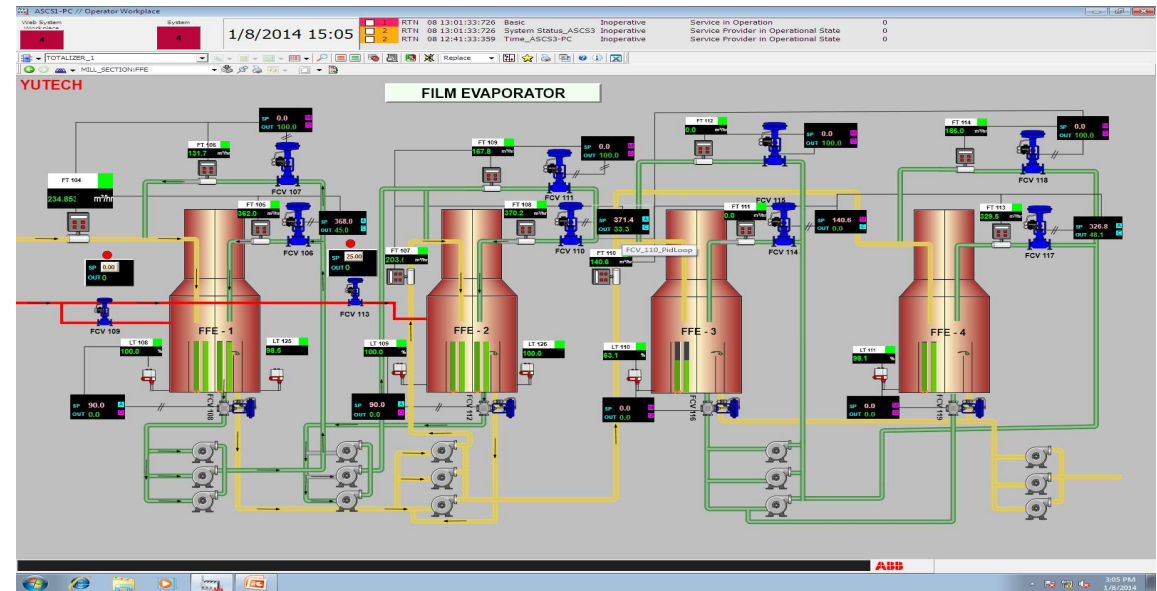

- FLUID-DENSITY-BRIX OF FINAL BODY MEASURED AND MAINTAINED
- INTELLIGENT DATA ANALYSIS WITH MAINTENANCE AND CLEANING ALARMING SYSTEM
- PRECEDING BODY LEVEL SYNCHRONIZATION FOR ALL BODIES INCLUDING JUICE TANKS AND CANE CARRIERS

YUTECH FLUID-DENSITY-BRIX ANALYZER CUM CONTROL SYSTEM AND MOTORIZED FLUID-DENSITY SENSOR

BATCH PAN AUTOMATION- BATCH PAN CONTROLS SCHEMATIC AND SCREENSHOT



YUTECH

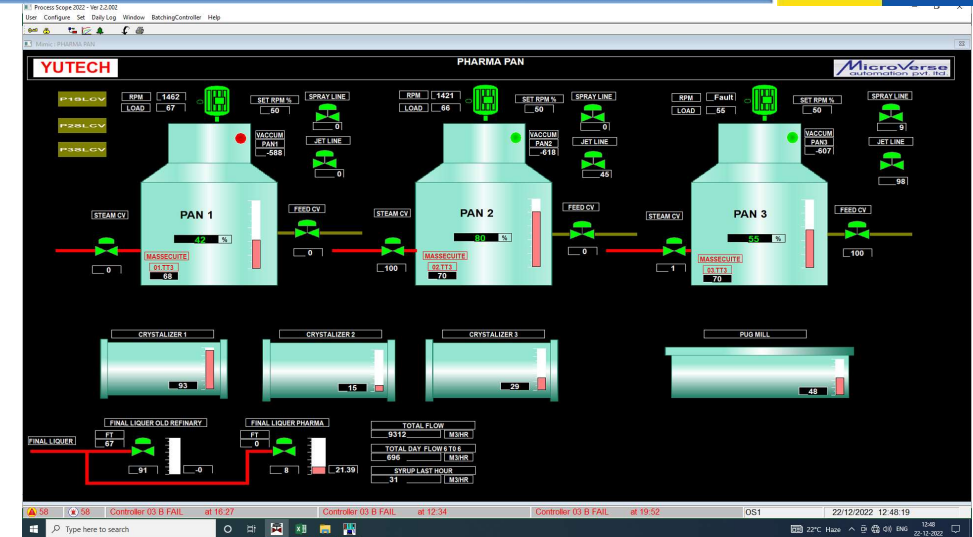
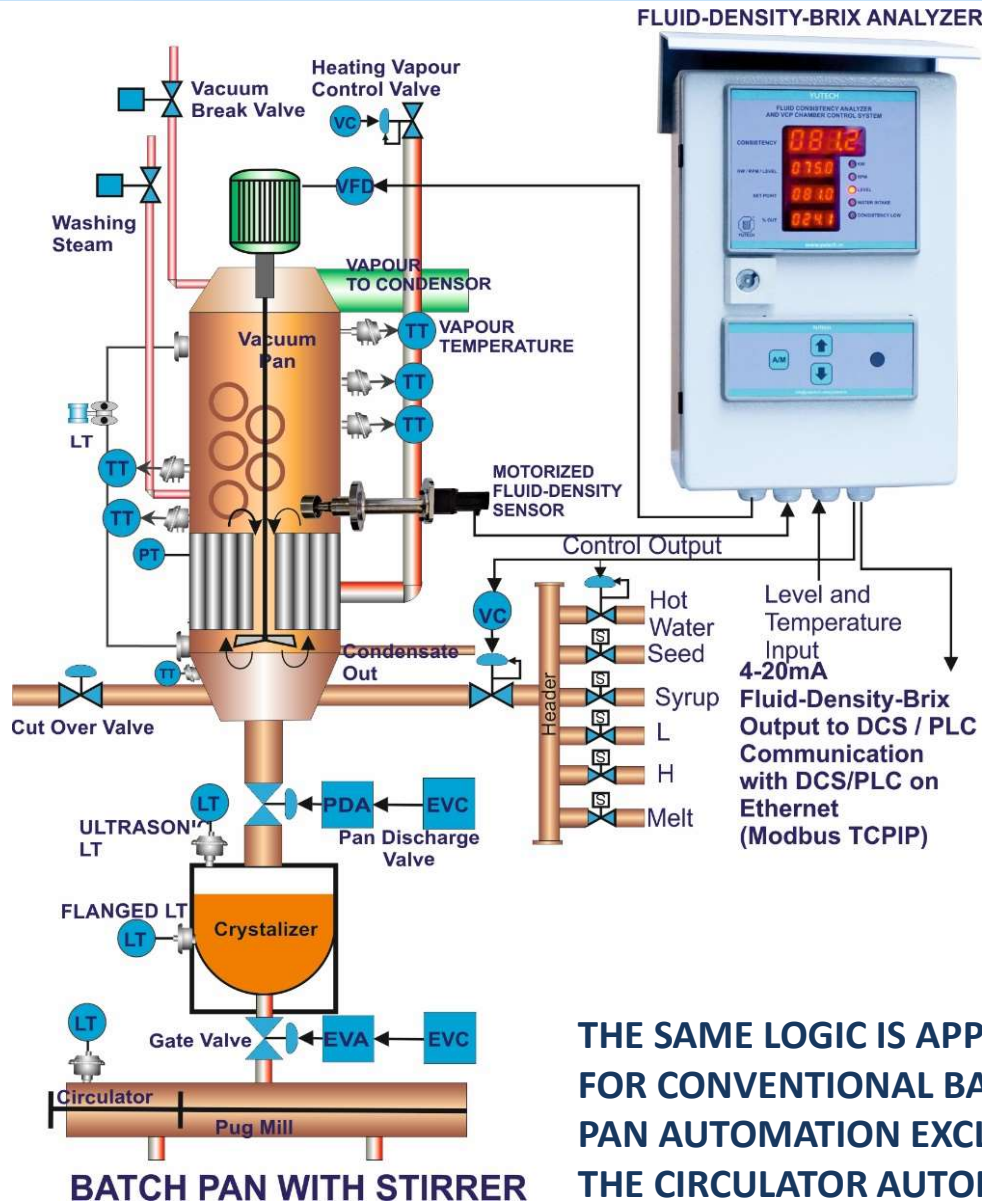

BATCH PAN AUTOMATION:

- FLUID-DENSITY-BRIX SENSING AND MATERIAL / WATER INTAKE CONTROL
- VARIABLE BRIX SET-POINT AS PER PAN LEVEL
- VFD SPEED CONTROL AS PER PAN LEVEL
- TEMPERATURE SENSING THROUGHOUT THE PAN TO ENSURE UNIFORM TEMPERATURE INSIDE PAN BODY
- BATCH COMPLETE INDICATION AND DROP SUGGESTION
- STANDALONE SYSTEM OR PLC / DCS BASED SYSTEM

YUTECH FLUID-DENSITY-BRIX ANALYZER CUM CONTROL SYSTEM AND MOTORIZED FLUID-DENSITY SENSOR BATCH PAN AUTOMATION- BATCH PAN CONTROLS SCHEMATIC AND SCREENSHOT



YUTECH

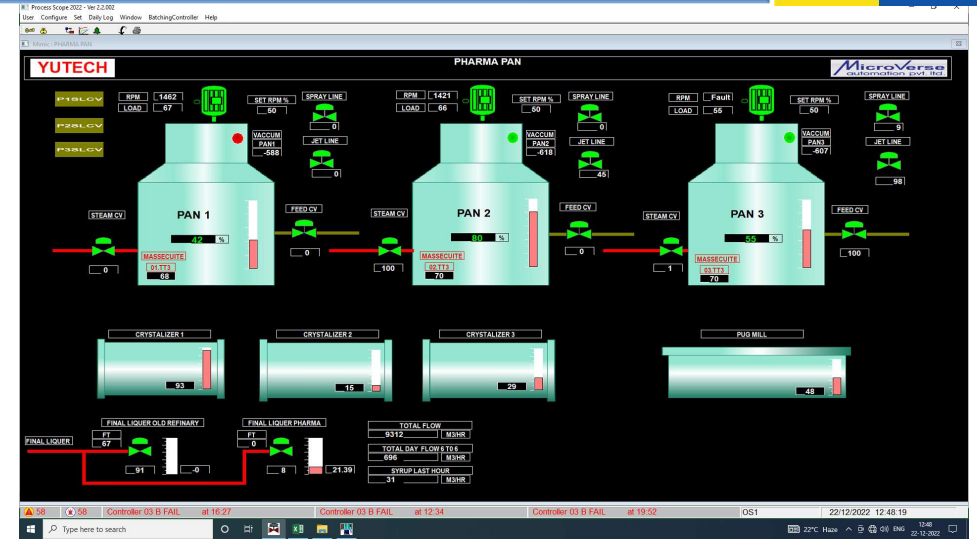
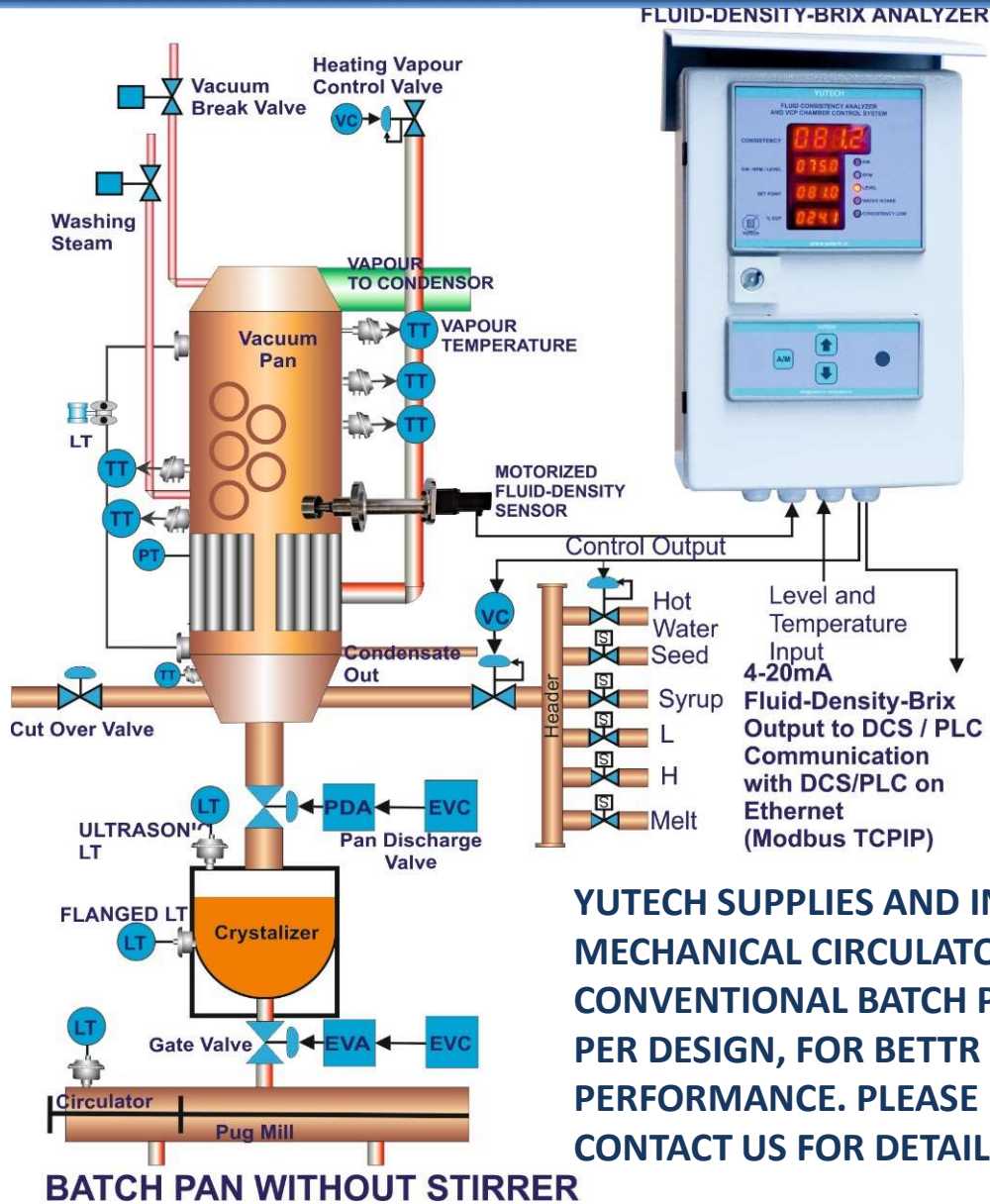

SCREEN SHOT: BATCH PAN AUTOMATION

BATCH PAN AUTOMATION:

- FLUID-DENSITY-BRIX SENSING AND MATERIAL / WATER INTAKE CONTROL
- VARIABLE BRIX SET-POINT AS PER PAN LEVEL
- VFD SPEED CONTROL AS PER PAN LEVEL
- TEMPERATURE SENSING THROUGHOUT THE PAN TO ENSURE UNIFORM TEMPERATURE INSIDE PAN BODY
- BATCH COMPLETE INDICATION AND DROP SUGGESTION
- STANDALONE SYSTEM OR PLC / DCS BASED SYSTEM

YUTECH FLUID-DENSITY-BRIX ANALYZER CUM CONTROL SYSTEM AND MOTORIZED FLUID-DENSITY SENSOR VERTICAL CONTINUOUS PAN AUTOMATION PAN CHAMBER CONTROL SCHEMATIC AND SCREENSHOT



YUTECH

FLUID-DENSITY-BRIX ANALYZER



MOTORIZED FLUID-DENSITY SENSOR AND FLUID-DENSITY-BRIX ANALYZER CUM VCP CHAMBER CONTROL SYSTEM STAND ALONE UNIT

DCS / PLC

DATA FOR DCS / PLC CONTROLS FOR VCP LOOPS ON MODBUS TCP/IP

PID CONTROL OUTPUT TO MATERIAL INTAKE VALVE

VFD

SPEED CONTROL OUTPUT VFD

PAN CHAMBER

MOTORIZED FLUID-DENSITY SENSOR

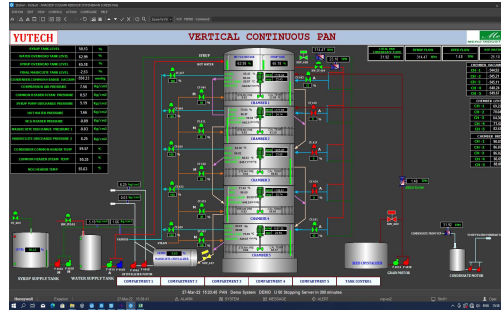

VERTICAL CONTINUOUS PAN AUTOMATION OVERALL SCREENSHOT

VERTICAL CONTINUOUS PAN AUTOMATION:

- ACCURATE FLUID-DENSITY-BRIX SENSING IN EACH COMPARTMENT ENSURES MAINTAINED BRIX THROUGHOUT THE CHAMBER AT ALL TIMES
- MAINTAINED BRIX ENSURES VERY LITTLE OR NO ADDITION OF WATER THUS INCREASING EFFICIENCY

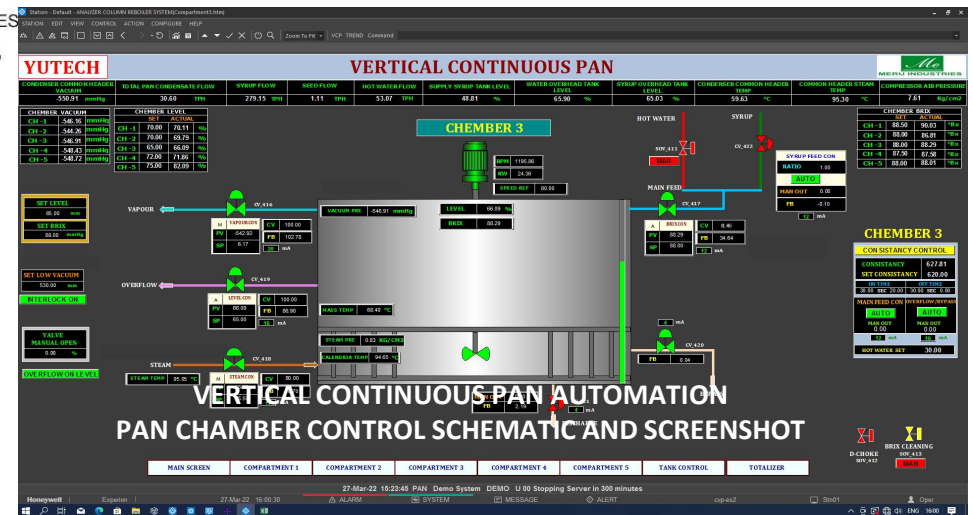
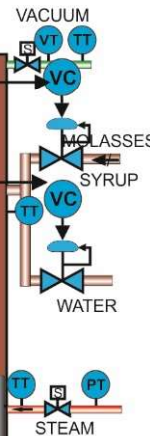

YUTECH FLUID-DENSITY-BRIX ANALYZER CUM CONTROL SYSTEM AND MOTORIZED FLUID-DENSITY SENSOR VERTICAL CONTINUOUS PAN AUTOMATION COMPARTMENT PAN BRIX VS BRIX SETPOINT TREND SCREEN SHOT



YUTECH

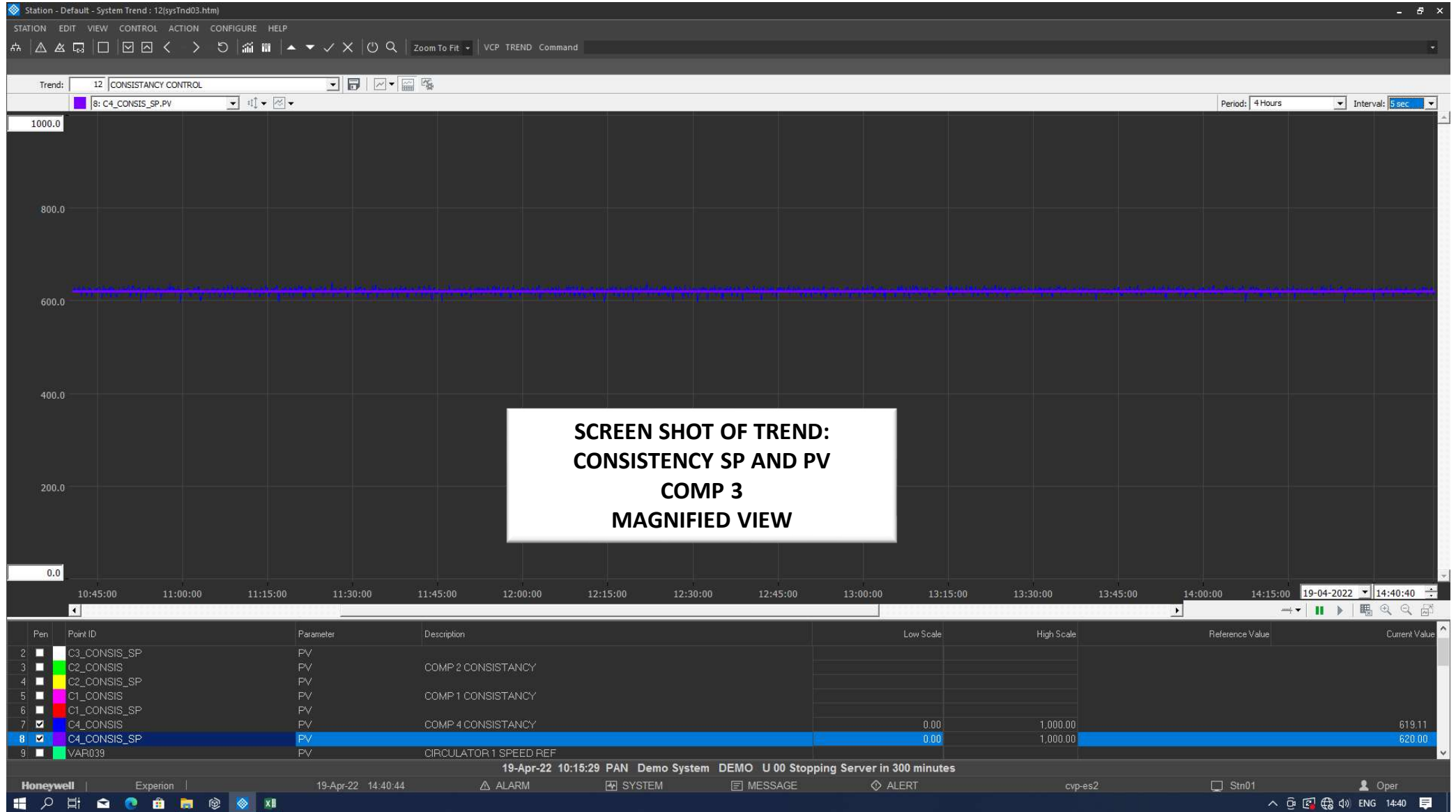

YUTECH FLUID-DENSITY-BRIX ANALYZER CUM CONTROL SYSTEM AND MOTORIZED FLUID-DENSITY SENSOR VERTICAL CONTINUOUS PAN AUTOMATION SCREENSHOT OVERALL VCP OR VKT



YUTECH

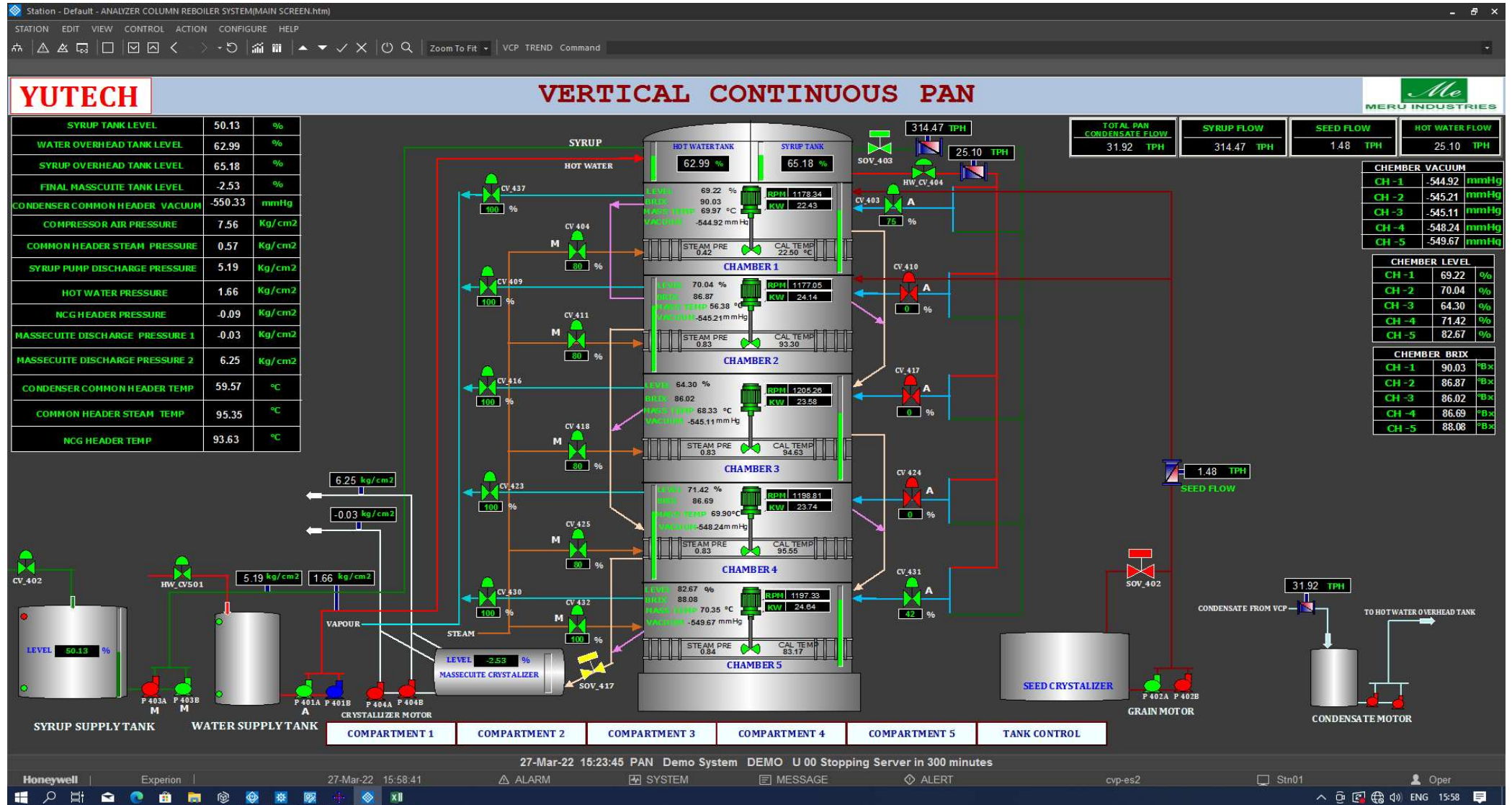

YUTECH FLUID-DENSITY-BRIX-ANALYZER CUM CONTROL SYSTEM AND MOTORIZED FLUID-DENSITY SENSOR CONTINUOUS VACUUM PAN AUTOMATION CVP CONTROL SCHEMATIC AND SCREENSHOT



YUTECH

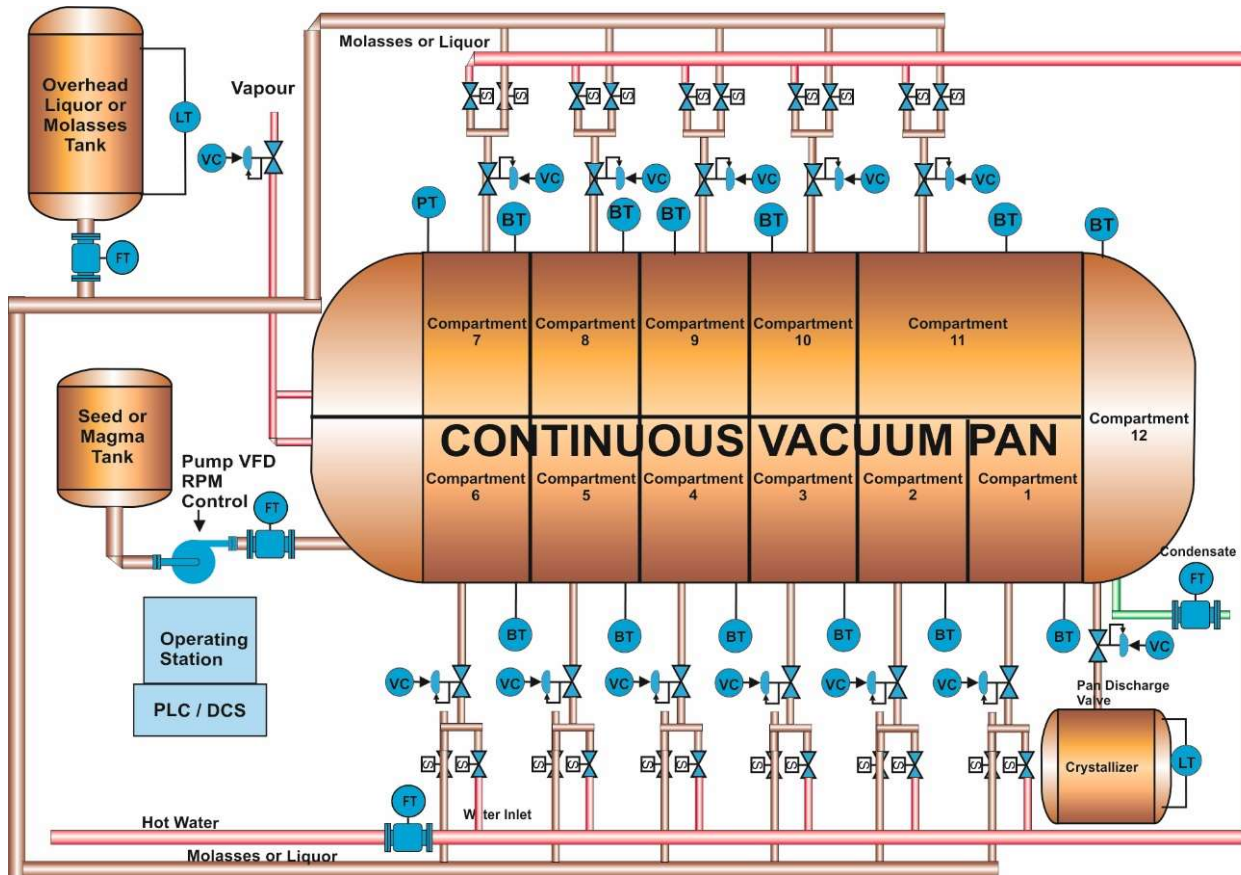

VERTICAL CONTINUOUS PAN AUTOMATION:

- CALENDRIA VAPOUR PRESSURE CONTROL
- STANDALONE SYSTEM FOR CV PAN HAVING COMMUNICATION WITH MAIN PLC / DCS SYSTEM

VERTICAL CONTINUOUS PAN AUTOMATION:

- SEED OR MAGMA FLOW CONTROL WITH RESPECT TO MOLASSES OR LIQUOR FLOW ENSURES MAINTAINED MOLASSES-TO-SEED RATIO
- YUTECH FLUID-DENSITY-BRIX OR YUTECH BRIX SENSING AND MOLASSES / WATER INTAKE CONTROL FOR EACH COMPARTMENT
- TEMPERATURE SENSING THROUGHOUT THE CV PAN ENSURES UNIFORM TEMPERATURE INSIDE THE CV PAN BODY

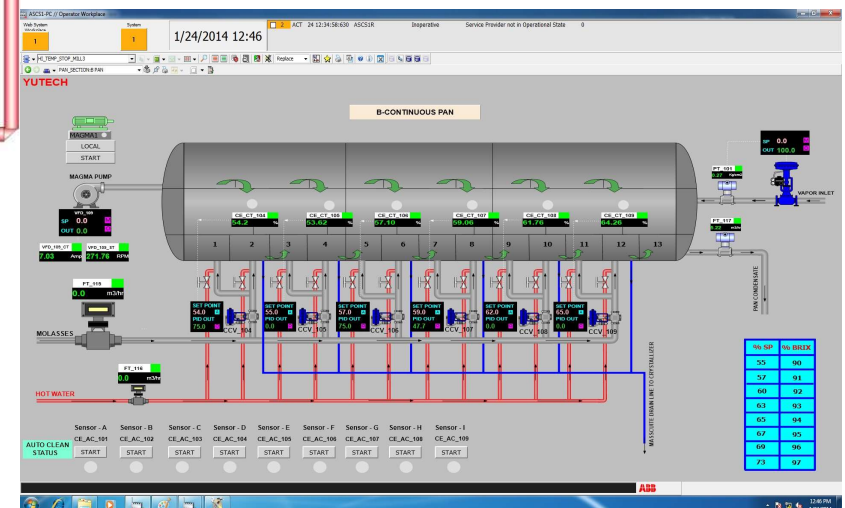

YUTECH FLUID-DENSITY-BRIX ANALYZER CUM CONTROL SYSTEM AND MOTORIZED FLUID-DENSITY SENSOR VERTICAL CONTINUOUS PAN AUTOMATION SCREENSHOTS FOR VARIOUS VCP CHAMBERS OR COMPARTMENTS



TRENDS OF VARIOUS COMPARTMENTS' BRIX CONTROLS

THE SYSTEM USES YUTECH'S BATCH PAN CONTROL ALGORITHM OR VERTICAL CONTINUOUS PAN CONTROL ALGORITHM WITH FLUID-DENSITY-BRIX AS THE MAIN SENSING PARAMETER.

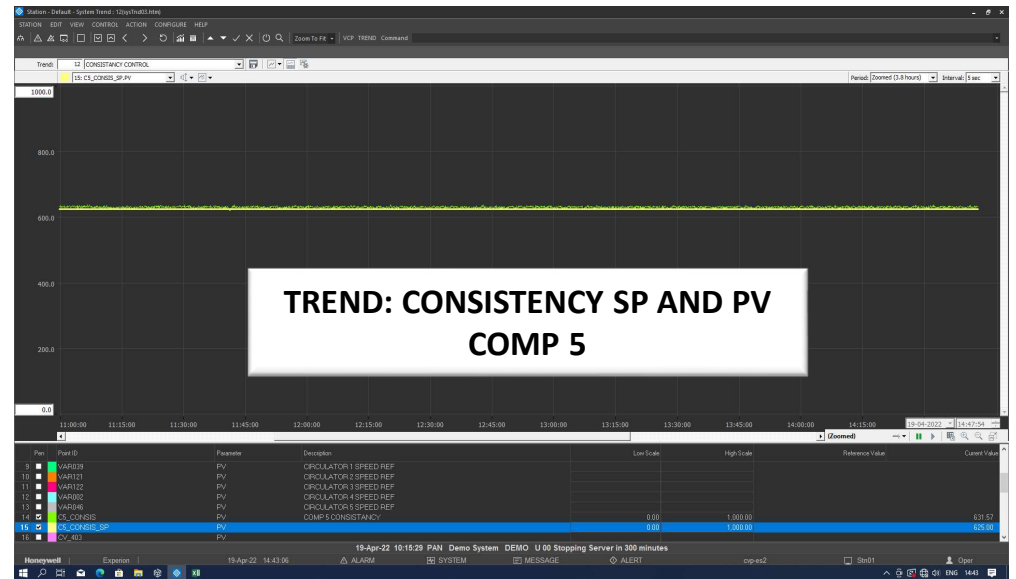
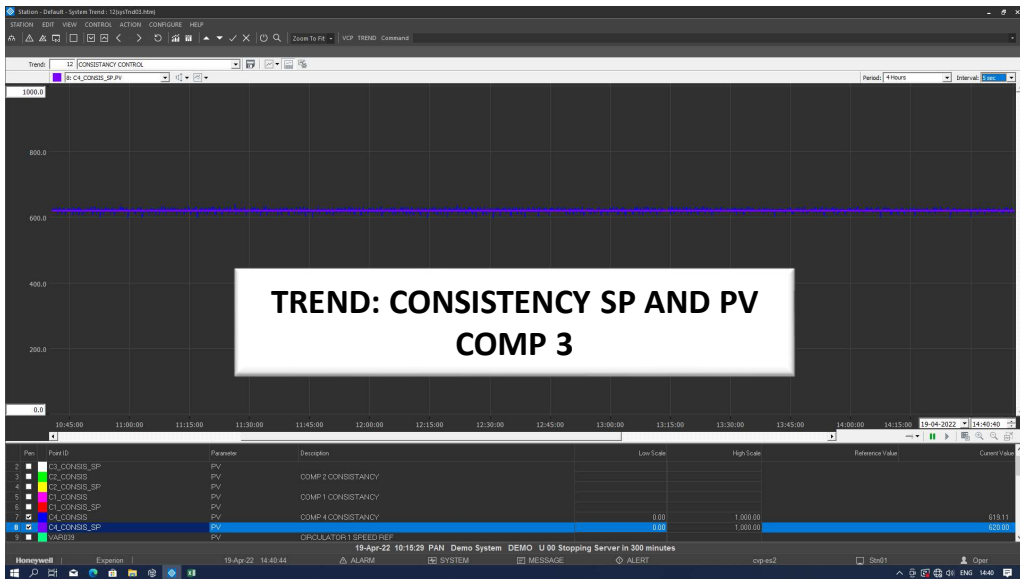
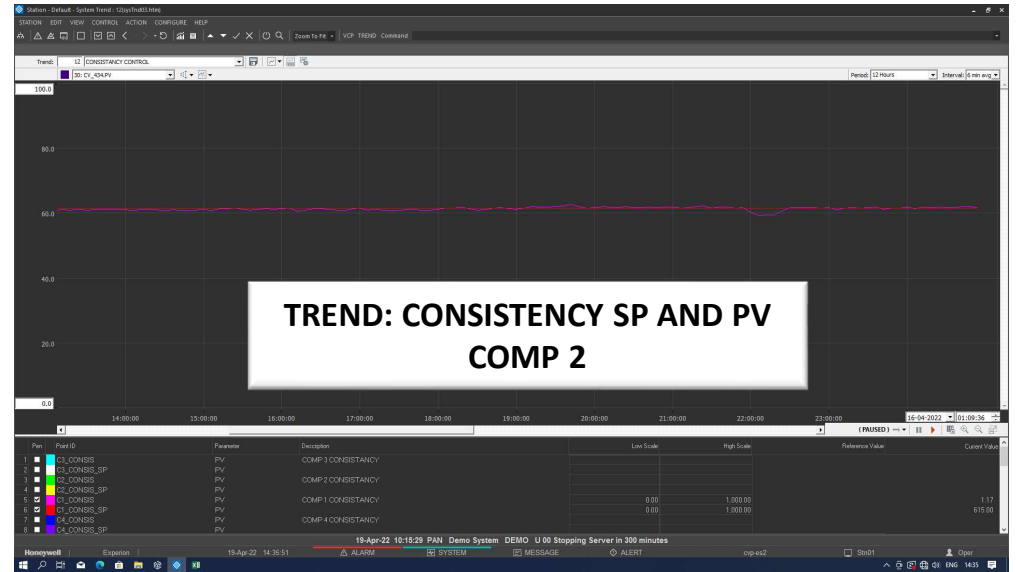

YUTECH FLUID-DENSITY-BRIX ANALYZER CUM CONTROL SYSTEM AND MOTORIZED FLUID-DENSITY SENSOR SUGAR MELTER AND MOLASSES CONDITIONER AUTOMATION SCREENSHOT, FIELD MOUNTING PICTURE, AND SCHEMATIC



YUTECH

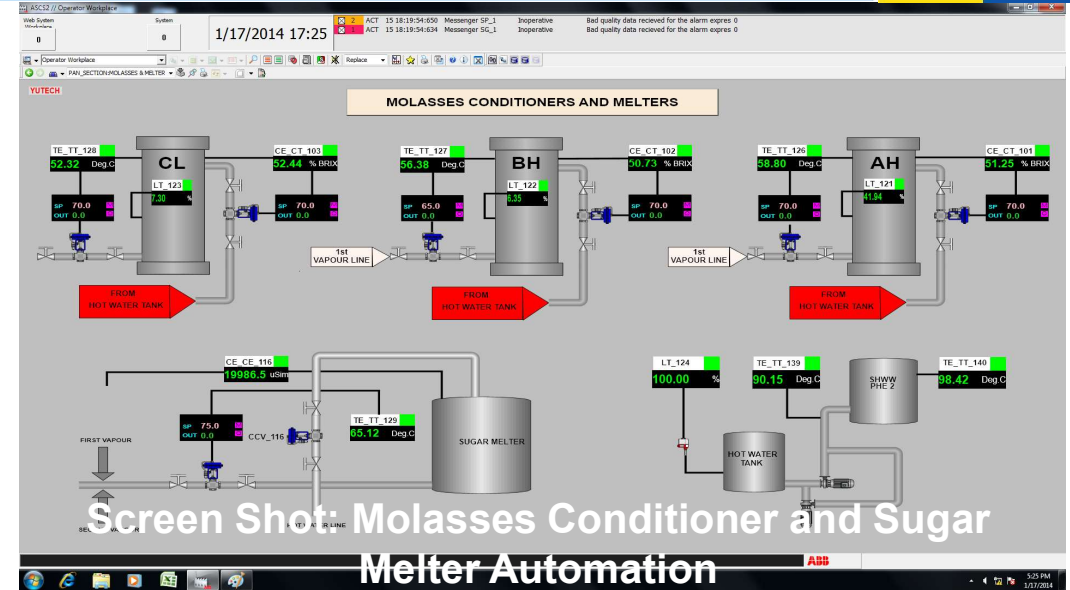

Schematic Diagrams: Molasses Conditioner and Sugar Melter Automation

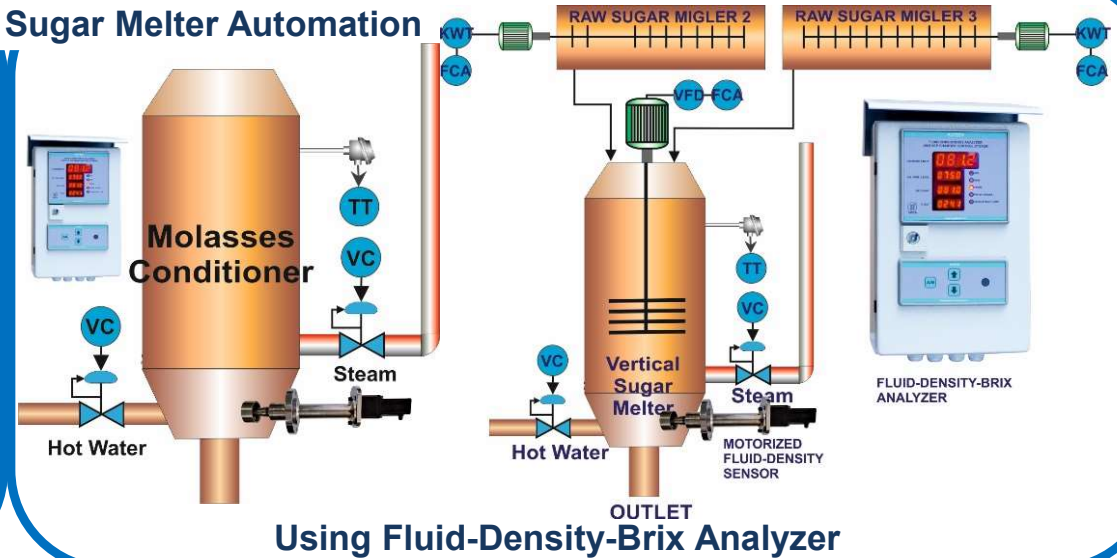
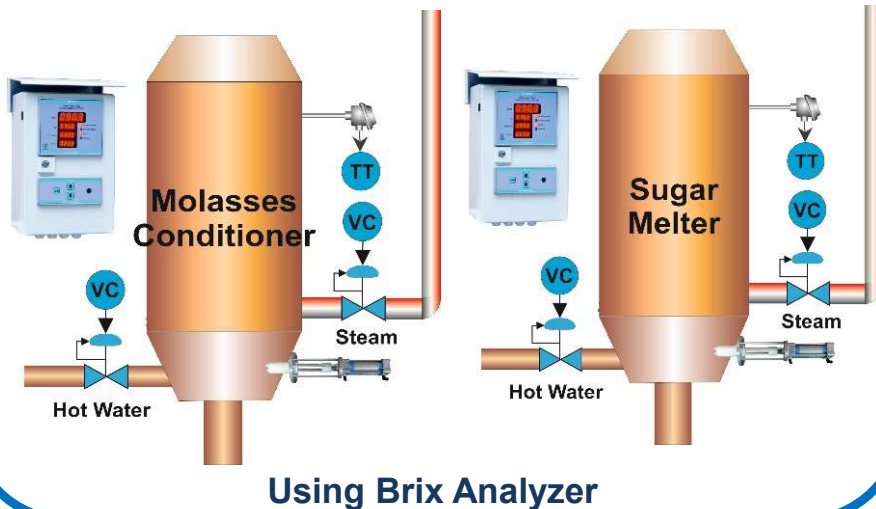

DCS or PLC Based Turnkey Automations or Standalone Control Systems:

- Complete Sugar Mill Automation with all Loops like Cane Feeding, Mill Speed Controls, Imbibition and Juice Flow Controls etc
- Complete Sugar Process Automation with Loops like Evaporator, Pans, Continuous Pans, Melters Conditioners, Direct Contact Heaters, Condensers etc
- Complete Sugar Refinery / Pharma Grade Sugar Plant Automation with Loops like Pans, Continuous Pans, Melters, Melt Clarifier, Melt Filtration Systems, Direct Contact Heaters, Condensers etc
- Complete Boiler and Power Plant Automation
- Complete Sugar Plant Automation and Instrumentation
- Complete Distillery Automation and Instrumentation
- Complete Process Plant (Pharma / Food Processing / Cement / Steel) Automation and Instrumentation
- VCP / CVP / Batch Pan Automation
- Condenser Automation
- Continuous Centrifugal Machine Automation based on CSD or Iris Valve
- Evaporator and FFE Automation
- Direct Contact Heater Automation
- Vertical Crystallizer
- pH Control System

YUTECH CONDENSER CONTROL SYSTEM FOR PANS AND EVAPORATORS

CONDENSER AUTOMATION USING YUTECH CONDENSER CONTROL SYSTEM

SCREEN SHOT: CONDENSER CONTROL SYSTEM IMPLEMENTED USING DCS / PLC



YUTECH

SCHEMATIC DIAGRAM AND SCREENSHOT: CONDENSER CONTROL

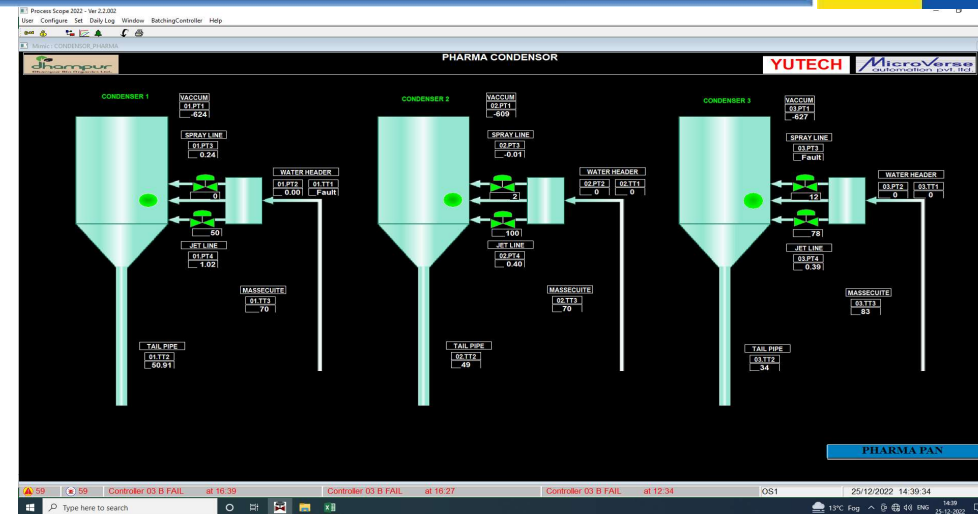
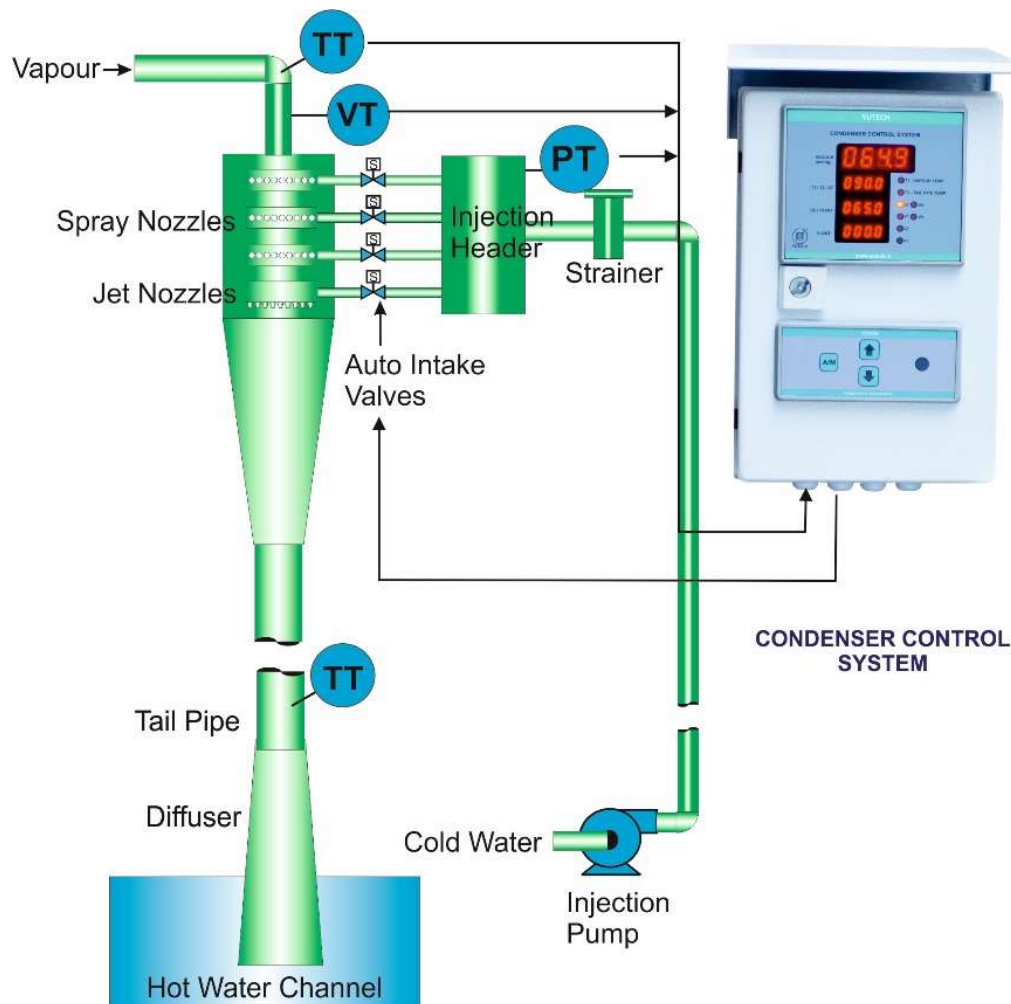

CONDENSER AUTOMATION:

- Separate Water Entry for Different Sets of Spray Nozzles and Spray Jet and Water Quantity is Automatically Controlled by ON/OFF Valve for Respective Nozzle Set Valve wrt Vacuum and Temperature difference between the Vapour and Condensate Tail Pipe
- Number of Jets & Nozzles and Jet & Nozzle Diameters designed as per Condenser Capacity
- Complete Stainless-Steel Construction, Strainer provided for each Condenser Header
- Water Pressure in the Common Injection Header maintained by Controlling Injection Pump VFD
- Jet Compartment Controlled by Separate Valve
- Vapour and Tail Pipe Temperature Measured

YUTECH'S INTELLIGENT A15 PLATFORM BASED ANALYZERS AND SYSTEMS:

INTELLIGENT & VERY POWERFUL, A15 PLATFORM HAS ANALYTICAL AND HIGHER I/O HANDLING ABILITY WITH COMMUNICATION FACILITY FOR ETHERNET AND WIRELESS PROTOCOLS



FIELD MOUNTED ANALYZERS AND CONTROL SYSTEMS FOR PROCESS, PHARMA, DAIRY AND SUGAR INDUSTRY:

SUGAR PROCESS ANALYZERS AND CONTROLS:

- **HIGH FREQUENCY BRIX ANALYZER AND BRIX ANALYZER AND AUTO-RETRACTABLE SELF-CLEANING BRIX SENSOR**
- **FLUID-DENSITY-BRIX ANALYZER CUM CONTROL SYSTEM AND MOTORIZED FLUID DENSITY SENSOR**
- **CONDUCTIVITY ANALYZER**
- **PH ANALYZER**
- **CONTINUOUS CENTRIFUGAL MACHINE AUTOMATION SYSTEM USING CONCENTRIC SPLIT DIAPHRAGM CONTROL VALVE ALSO CALLED IRIS VALVE.**
- **CONDENSER CONTROL SYSTEM: MULTIPLE OR SINGLE WATER SPRAY AND JET ENTRY CONDENSER CONTROLS.**

SUGAR MILL AND BOILER ANALYZERS AND CONTROLS:

- **INFRA RED TYPE LEVEL SENSING AND TRANSMISSION SYSTEM: SUGAR MILL DONNELLY CHUTES.**
- **INFRA RED TYPE LEVEL SENSING AND TRANSMISSION SYSTEM: BOILER BAGASSE SILOS OR CHUTES.**
- **CAPACITIVE TYPE LEVEL SENSING AND TRANSMISSION SYSTEM: SUGAR MILL DONNELLY CHUTES.**

DATA ACQUISITION AND COMMUNICATION:

- **FIELD MOUNTED DATA ACQUISITION AND COMMUNICATION SYSTEM: ETHERNET / WIRELESS COMMUNICATION**
- **IOT FIELD MOUNTED DATA ACQUISITION AND COMMUNICATION SYSTEM: PROCESS DATA TRANSMISSION AND INTERNET COMMUNICATION ON GSM AND WIFI**
- **16 CHANNEL SCANNER WITH MODBUS RTU**
- **16 CHANNEL SCANNER WITH MODBUS TCP/IP**



YUTECH

YUTECH SUGAR MILL PROCESS INSTRUMENTS

MEASURING SUGARS BRIX BY BRIX

YUTECH FLOW CONTROLS

CONTROL SAVE EARN

YUTECH AUTOMATION

THE SWEETENER TO SUCCESS

YUTECH INSTRUMENTS

ANALYZE TRANSMIT CONTROL COMMUNICATE

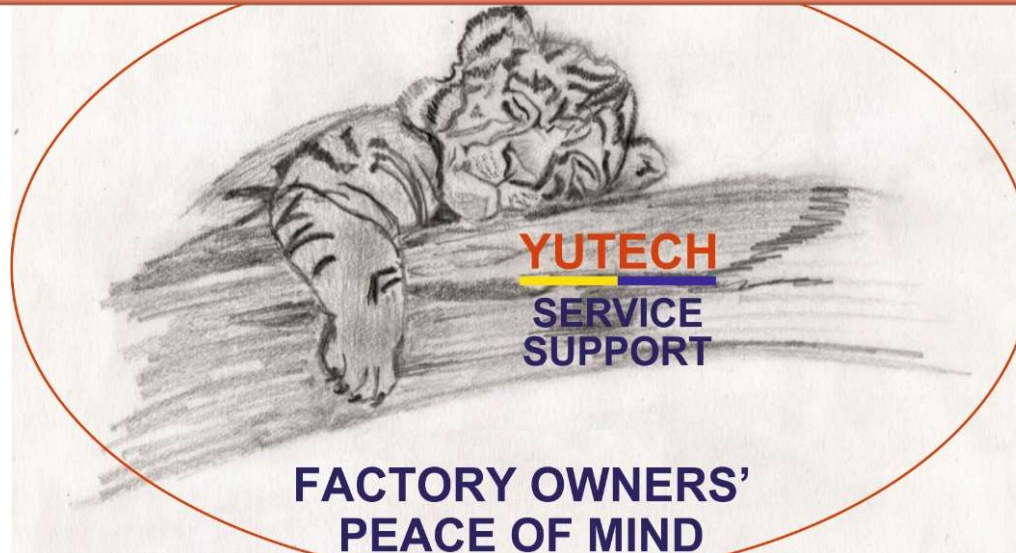

FACTORY OWNERS'
PEACE OF MIND

**SAVE FUEL, REDUCE CARBON FOOTPRINT,
MAKE THE WORLD GREENER
AND YET, MAKE MONEY**

THANK YOU

www.yutechautomation.com; www.yutech.in; sale@yutech.in